

# TD



**tecnoclima**  
agriculture

since 1973

EN

*Tecnoclima is the leading Italian company that has been operating in the Warm Air Heating market for 40 years, offering solutions and products for the agricultural sector. Our products are entirely designed and manufactured in Italy at our production plants, according to the regulations in force in various international markets and subjected to the strongest quality and reliability controls. Innovation, technology and customer orientation have always been the hallmarks of our proposal.*

*The commercial organization of Tecnoclima supports the customer in identifying the best solutions and our technical service provides timely and comprehensive support after installation.*

*The peculiarity of the warm air heating system is to directly transfer the thermal energy to the space to heat with no use of intermediate fluids such as water. The system therefore does not need to have space for a boiler and the installation of pumps, valves, storage tanks, pipes and water treatment systems, reducing installation costs and time as well as maintenance costs. Furthermore, the absence of an intermediate fluid means a very low thermal inertia, allowing to reach the required room temperature in a very short time and to adapt quickly to the sudden weather conditions changes, with a significant fuel saving as a result.*

*Tecnoclima warm air heaters for agricultural applications have been designed considering farmers' needs and experience accumulated in thousands of successful installations:*

- simple and quick installation
- accessories to fit the different types of solutions
- reliable and durable operation
- ideal heating level for different types of plants
- consumption economy thanks to the high efficiency
- choice of the highest quality materials suitable for use in greenhouses
- technical assistance service

*AGRI warm air heaters enjoy great success both in Italy and in the foreign markets thanks to their reliability, efficiency, safety and versatility. The range has been updated over the years and today offers heating capacity from 60 to 240 kW and installation solutions that allow it to be adapted to any greenhouse system.*

*The latest news in the AGRI series is the "down flow" model that takes air at the top of the heater and send it to ground level through a main and secondary network of sleeves. This execution has already gained great success in the TC-DF series, a range of warm air heater for large-scale greenhouses and intensive vegetables and flower production. Warm air diffusion in the lower part of the greenhouse ensures targeted plant heating at the ground level and an optimal mixing of air throughout the greenhouse, ensuring a high overall system efficiency.*

*Thousands of pieces sold every year confirm the farmers' credit around the world. The wide range of Tecnoclima products is constantly updated to meet the peculiarities of the technical standards and installation types of the different countries in which they are exported.*

*Tecnoclima actively participates in all major agricultural events, such as AgraME Dubai, Saudi Agriculture Saudi Arabia, Agritechnica Germany, Flormart Italy, Caspian Agro Azerbaijan, Greenhouses Kazakhstan, Fruit Logistics Germany, Agroalimentary Expo Guanajuato Mexico, Sival France etc.*

*Tecnoclima stands out from its competitors for the ability to propose appropriate solutions to any kind of request in the agricultural world. Versatility, creativity and reliability, coupled with a longstanding internationally recognized experience, represent the distinctive features of our proposal.*



**AgraME Dubai**



**Caspian Agro Azerbaijan**

## **AGRI-DF**

**new**

Warm air heaters with heat exchanger, gas or diesel fired.

PAGES 4-5

## **AGRI-P**

Suspended warm air heaters with heat exchanger, gas or diesel fired.

PAGES 6-7

## **AGRI-C**

Mobile warm air heaters with heat exchanger, gas or diesel fired.

PAGES 8-9

## **TC-DF**

Cabinet warm air heaters with heat exchanger, gas or diesel fired.

PAGES 10-11

## **TCO-DF**

Horizontal cabinet warm air heaters with heat exchanger, gas or diesel fired.

PAGES 12-13

## **SUPERCIKKI 80**

Direct-fired gas air heater.

PAGES 14-15

## **AZN-X**

Water heaters suitable for agricultural applications.

PAGES 16-17

## **DAE**

Air diffusers.

PAGE 18

## **INSTALLATION EXAMPLES**

PAGES 19-23

# SERIES

# AGRI-DF



**Warm air heaters with heat exchanger, gas or diesel fired: maximum cultivations productivity, thanks to the capillary diffusion of warm air at the base of the plants**



#### CERTIFIED IN ACCORDANCE WITH:

- MACHINE DIRECTIVE 2006/42/CE
- LOW TENSION DIRECTIVE 2006/95/CE
- ELECTROMAGNETIC COMPATIBILITY DIRECTIVE 2004/108/CE

**AGRI-DF** warm air heater was designed as the answer to the growing need of farmers to heat greenhouses with down-flow air diffusion system. **A widespread diffusion of warm air at the base of the plants ensures healthy, faster and more intense growth.** The warm air heating system allows intermittent operation (only when needed during the coldest hours of the day) and occasional use (only in the cold months of the year), it guarantees also a significant reduction in investment costs and a sure operation saving.

**AGRI-DF** warms up with clean air, avoiding introduction of harmful combustion residues and also helps to reduce excessive humidity in the environment. The use of clean air and humidity reduction allow to limit ventilation with obvious benefits in terms of energy saving and quality of the growth environment for crops.

**AGRI-DF** warm air heater adopts best technical solutions, components and materials, designed to provide the best heating and ventilation performance and accurately selected to ensure reliable operation over the years. The heat exchanger is entirely made of corrosion resistant stainless steel Aisi 430. The use of blown burners (gas or diesel) allows safe and reliable operation even in harsh environments. The ventilation section is made up of a special axial fan with protection grid, characterized by high pressure and silent operation. The unit is equipped with control and safety thermostats. The cabinet is made of galvanized pre-painted steel panels.

**AGRI-DF significantly improves plant growth, ensuring the required amount of heat at the most suitable temperature in relation to the life cycle of the plant.**

## MAIN COMPONENTS

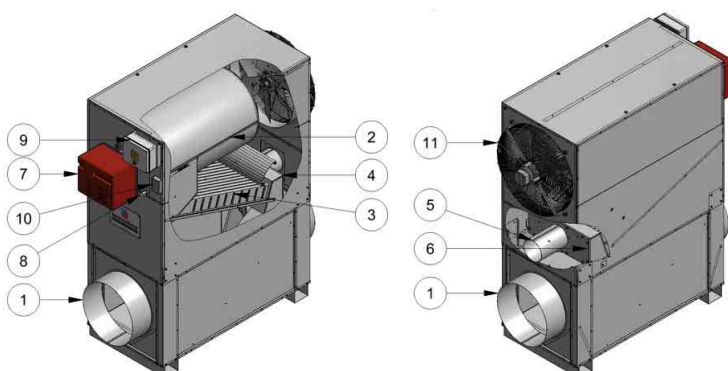

1. Warm air outlet connection.
2. Combustion chamber.
3. Heat exchanger.
4. Exhaust manifold.
5. Exhaust duct connection.
6. Inspection door exhaust manifold.
7. Blown burner.
8. Flame visor.
9. Electric board.
10. FAN-LIMIT thermostat.
11. Axial fan.

## AGRI-DF: air diffusion example

The diagram shows an example of warm air diffusion through metal main channels and polyethylene secondary sleeves with the outlet holes situated at the appropriate distance to ensure uniform air diffusion over the entire length of the channels. Secondary sleeves are positioned along the crops rows **to heat directly the plant base**, increasing the intensity of growth and development of intensive greenhouse cultivation. With the **down-flow** heating system, more frequent cultivation cycles are promoted, increasing the productivity of the greenhouse.

The **"down-flow"** air diffusion system reproduces the concept of "drip irrigation", ensuring targeted and capillary crop heating only where it serves, at the time of actual need, with no fuel or energy waste.



## DIMENSIONS

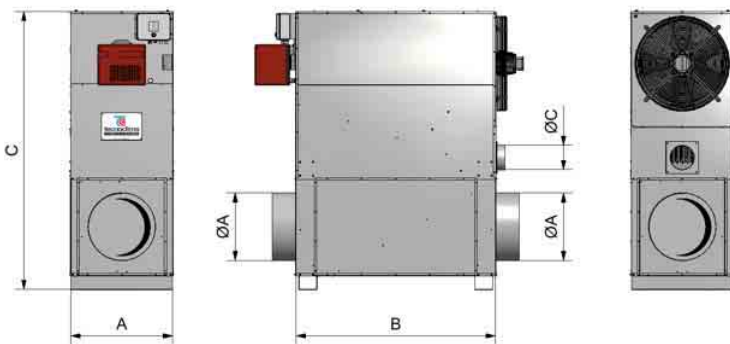

Dimension	U.M.	Value
A	mm	750
B	mm	1.470
C	mm	2.030
Ø A	mm	500
Ø C	mm	180
NET WEIGHT	Kg	260

## TECHNICAL SPECIFICATIONS

## SERIES AGRI-DF

Model AGRI-DF	U.M.	175
Heating capacity INPUT	kW	175,0
	kcal/h	150.500
Heating capacity OUTPUT	kW	152,3
	kcal/h	130.970
Air flow	m³/h	12.500
Useful static pressure	Pa	110
Electrical power	kW	2,2
Electrical supply	Three phase	400V - 50Hz 3N

Technical features certified

# SERIES

# AGRI-P

**Suspended warm air heaters  
with heat exchanger, gas or diesel  
fired: versatile installation, safe  
and easy operation**

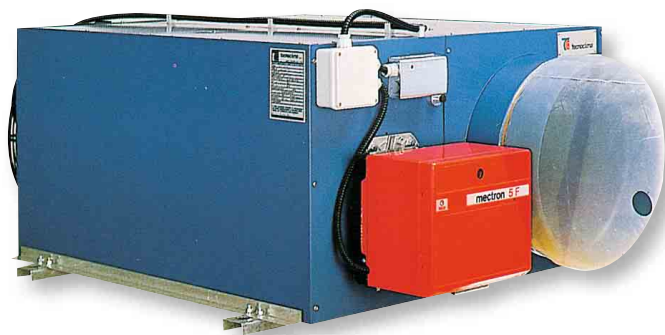

**CERTIFIED IN ACCORDANCE WITH:**

**MACHINE DIRECTIVE 2006/42/CE**

**LOW TENSION DIRECTIVE 2006/95/CE**

**ELECTROMAGNETIC COMPATIBILITY  
DIRECTIVE 2004/108/CE**

The **AGRI-P** series offers suspended vertical and horizontal installation models. The **AGRI-P** warm air heater adopts best technical solutions, components and materials, designed to provide the best heating and ventilation performance and accurately selected to ensure reliable operation over the years. **The heat exchanger** is entirely made of corrosion resistant stainless steel Aisi 430. The use of **blown burners** (gas or diesel) allows **safe and reliable operation** even in harsh environments.

The heaters are available with high-performance axial or centrifugal fans in versions **AGRI-P/R** to fit different systems requirements. The unit is equipped with control and safety thermostats. The cabinet is made of galvanized pre-painted steel panels.

**AGRI-P** warms up with clean air, avoiding introduction of harmful combustion residues and also helps to **reduce excessive humidity in the environment**. The use of clean air and humidity reduction allow to limit ventilation with obvious benefits in terms of energy saving and quality of the growth environment for crops.

**AGRI-P** is available in 7 models with a full range of accessories for direct or indirect diffusion by channels.

**AGRI** is the modular and flexible solution for every investment in the agricultural sector, from industrial greenhouses for intensive production of vegetables to open-to-public gardens.

**AGRI** heaters are also successfully applied in livestock heating.

## THE SPECIFIC BENEFITS OF THE SUSPENDED VERSION

- ✓ **No space occupied on the ground** increasing cultivations area
- ✓ **The installation can be permanent**, there is no need to remove the heater at the end of the season.
- ✓ **The installation in the head of greenhouse** allows external fresh air intake and the front output of the chimney avoiding to hole the cover.
- ✓ **Irrigation water** does not directly affect the heater.
- ✓ **Agri-P series heaters with axial fan can be installed indifferently in both vertical and horizontal positions to better adapt to the geometry of the greenhouse.**



## DIMENSIONS

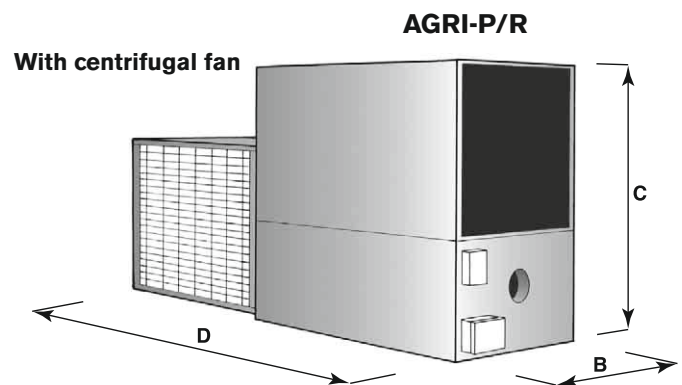
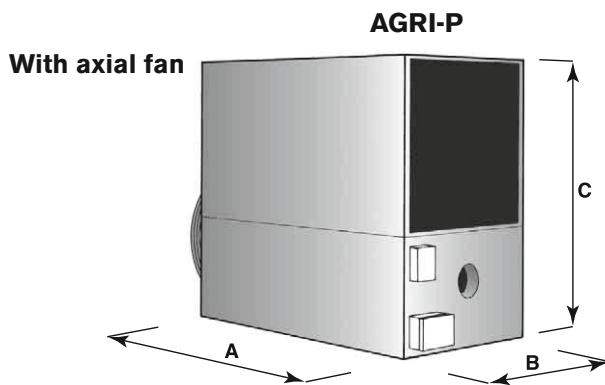

Model	Dimensions mm				Chimney Ø mm	* Weight Kg	
	A	B	C	D		AGRI-P	AGRI-P/R
<b>AGRI-P AGRI-P/R 60</b>	1.170	500	860	1.620	130	92	115
<b>AGRI-P AGRI-P/R 85</b>	1.170	550	925	1.715	130	107	132
<b>AGRI-P AGRI-P/R 120</b>	1.430	650	1.080	2.045	180	160	191
<b>AGRI-P AGRI-P/R 135</b>	1.430	650	1.080	2.045	180	170	201
<b>AGRI-P AGRI-P/R 150</b>	1.570	650	1.150	2.185	180	182	213
<b>AGRI-P AGRI-P/R 175</b>	1.690	750	1.230	2.420	180	220	275
<b>AGRI-P 240</b>	2.020	950	1.500	-	200	390	-

## TECHNICAL SPECIFICATIONS

## SERIES **AGRI-P**

Model AGRI-P, AGRI-P/R		U.M.	60	85	120	135	150	175	240
Heating capacity input	<b>kW</b>		60,0	85,0	115,9	137,0	148,0	175,0	240,0
	<b>kcal/h</b>		51.600	73.100	99.700	117.800	127.280	150.500	206.400
Heating capacity output	<b>kW</b>		52,2	73,9	100,8	120,6	128,8	152,3	216,2
	<b>kcal/h</b>		44.890	63.590	86.680	103.716	110.734	130.930	185.930
Air flow at +15°C		<b>m³/h</b>	4.100	5.700	8.300	9.500	9.600	12.500	18.400
Electrical power	axial fan	<b>kW</b>	0,40	0,54	1,00	1,30	1,30	1,30	2,60
	centrifugal fan	<b>kW</b>	0,75	0,75	1,50	1,50	1,50	2,20	-
Electrical supply	Single phase	<b>V - 50Hz</b>	230 ~	230 ~	230 ~	-	-	-	-
	Three phase	<b>V - 50Hz</b>	-	400 3N~	400 3N~	400 3N~	400 3N~	400 3N~	400 3N~

Technical features certified

# SERIES

# AGRI-C



**Mobile warm air heaters with heat exchanger, gas or diesel fired: versatile installation, safe and easy operation.**

**CERTIFIED IN ACCORDANCE WITH:**

**MACHINE DIRECTIVE 2006/42/CE**

**LOW TENSION DIRECTIVE 2006/95/CE**

**ELECTROMAGNETIC COMPATIBILITY  
DIRECTIVE 2004/108/CE**

The **AGRI-C** series offers mobile models. The **AGRI-C** warm air heater adopts best technical solutions, components and materials, designed to provide the best heating and ventilation performance and accurately selected to ensure reliable operation over the years. **The heat exchanger** is entirely made of corrosion resistant stainless steel Aisi 430. The use of **blown burners** (gas or diesel) allows **safe and reliable operation** even in harsh environments.

The heaters are available with high-performance axial or centrifugal fans in versions **AGRI-C/R** to fit different systems requirements. The unit is equipped with control and safety thermostats. The cabinet is made of galvanized pre-painted steel panels.

**AGRI-C** warms up with clean air, avoiding introduction of harmful combustion residues and also **helps to reduce excessive humidity in the environment**. The use of clean air and humidity reduction allow to limit ventilation with obvious benefits in terms of energy saving and quality of the growth environment for crops.

**AGRI-C** is available in 7 models with a full range of accessories for direct or indirect diffusion by channels. **AGRI** is the modular and flexible solution for every investment in the agricultural sector, from industrial greenhouses for intensive production of vegetables to open-to-public gardens.

**AGRI** heaters are also successfully applied in livestock heating.

## SPECIAL HEAT EXCHANGER IN INOX: THE HEART OF WARM AIR HEATER



High-efficiency heat exchanger with countercurrent airflow compared to the smoke flue flow, totally made of 18% chrome-plated stainless steel, which guarantees full protection against corrosion both from ambient humidity and from combustion.

**The heat exchanger consists of:**

- flame inversion combustion chamber with cylindrical shape, perfectly cooled at every point, with burner inlet and spy for visual inspection of the flame
- heat exchanger with inclined flat tubular smoke pipes with special prints for maximum thermal performance.





## DIMENSIONS

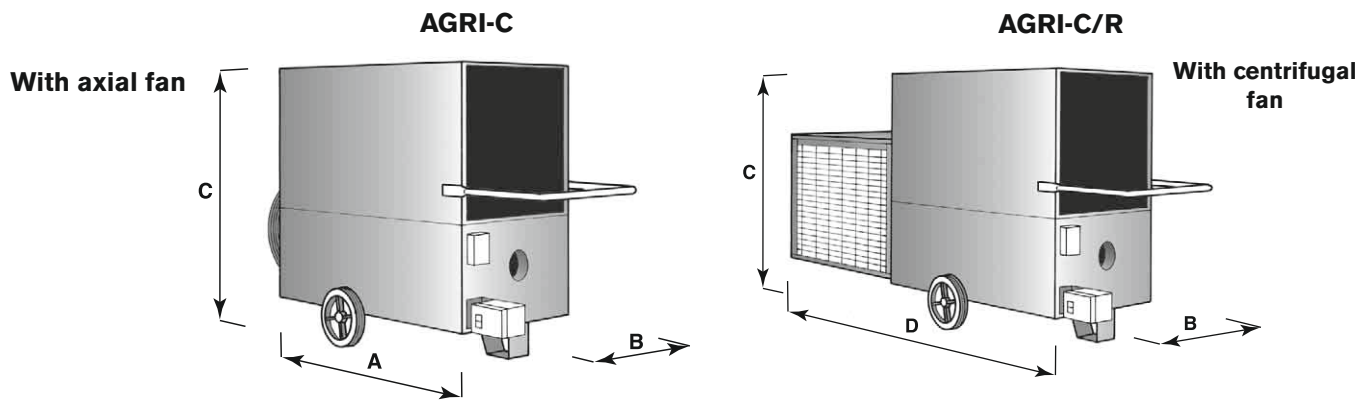

Model	Dimensions mm				Chimney Ø mm	* Weight Kg	
	A	B	C	D		AGRI-C	AGRI-C/R
AGRI-C AGRI-C/R 60	1.440	670	1.000	1.890	130	96	119
AGRI-C AGRI-C/R 85	1.440	720	1.065	1.985	130	114	137
AGRI-C AGRI-C/R 120	1.720	820	1.220	2.330	180	168	199
AGRI-C AGRI-C/R 135	1.780	900	1.250	2.330	180	182	213
AGRI-C AGRI-C/R 150	1.910	900	1.320	2.470	180	195	226
AGRI-C AGRI-C/R 175	1.910	910	1.400	2.690	180	230	285
AGRI-C 240	2.320	1.130	1.700	-	200	390	-

## TECHNICAL SPECIFICATIONS

## SERIES AGRI-C

Model AGRI-C, AGRI-C/R	U.M.	60	85	120	135	150	175	240
Heating capacity input	kW	60,0	85,0	115,9	137,0	148,0	175,0	240,0
	kcal/h	51.600	73.100	99.700	117.800	127.280	150.500	206.400
Heating capacity output	kW	52,2	73,9	100,8	120,6	128,8	152,3	216,2
	kcal/h	44.890	63.590	86.680	103.716	110.734	130.930	185.930
Air flow at +15°C	m³/h	4.100	5.700	8.300	9.500	9.600	12.500	18.400
Electrical power	axial fan kW	0,40	0,54	1,00	1,30	1,30	1,30	2,60
	centrifugal fan kW	0,75	0,75	1,50	1,50	1,50	2,20	-
Electrical supply	Single phase V - 50Hz	230 ~	230 ~	230 ~	-	-	-	-
	Three phase V - 50Hz	-	400 3N~	400 3N~	400 3N~	400 3N~	400 3N~	400 3N~

Technical features certified

# SERIES

# TC-DF



**Warm air heater with heat exchanger, gas or diesel fired: a widespread diffusion of warm air at the base of the plants**

**CERTIFIED IN ACCORDANCE WITH:**

**MACHINE DIRECTIVE 2006/42/CE**

**GAS DIRECTIVE 2009/142/CE**

**LOW TENSION DIRECTIVE 2006/95/CE**

**ELECTROMAGNETIC COMPATIBILITY  
DIRECTIVE 2004/108/CE**

High efficiency warm air heater **TC “down-flow”** series vertical version with gas or diesel blown burner provides warm air to be supplied mainly to greenhouse structures, but also in all cases where an air-to-ground diffusion system is required. The equipment consist mainly of an isolated cabinet receiving the air flow produced by the ventilator group. The cabinet contains a high-efficiency inox Aisi 430 stainless steel heat exchanger which transfers the thermal power by means of direct exchange between combustion products and the air flow to be treated. The warm air heater with air diffusion system consisting of main sleeves with secondary branch sleeves, **allows the targeted heating of plant’s base granting a more intensive growth and a global energy saving.** The centrifugal fan’s characteristics make the equipment suitable to be installed where air is to be distributed through air channels or more generally where high static pressure is required. The warm air heater is complete with electrical device for heater functions control and a particular flange for the connection to air channels. On request all the models can be matched with double stage or modulating burners for the total control of the greenhouse's temperature. This allows to reach the maximum global plant efficiency.

## TC-DF: installation example in the greenhouse with cultivations on tables

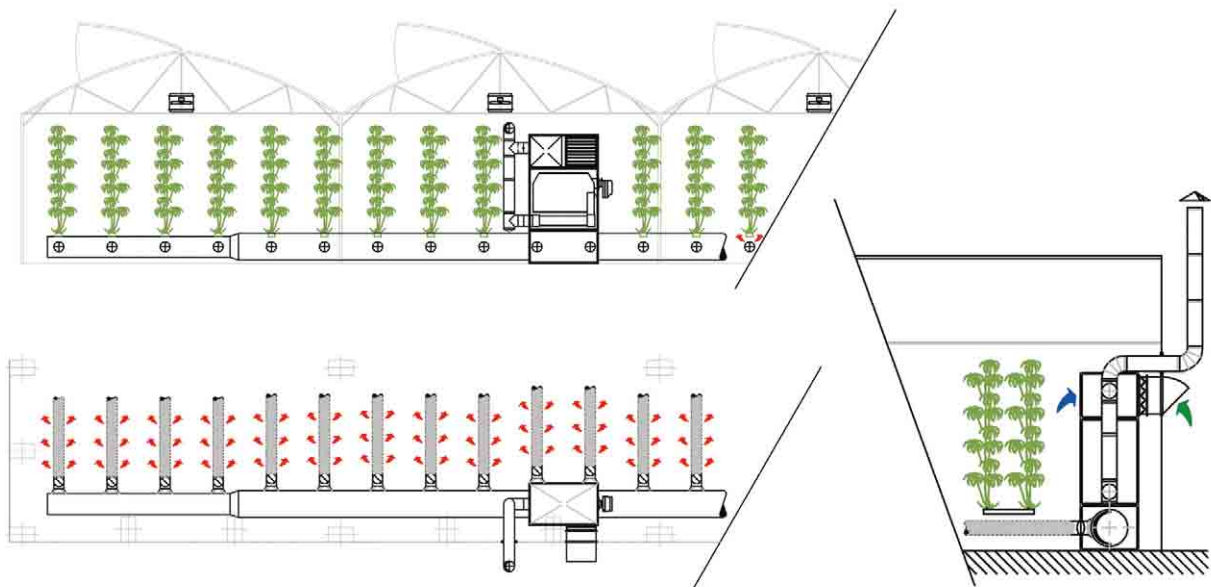



## DIMENSIONS

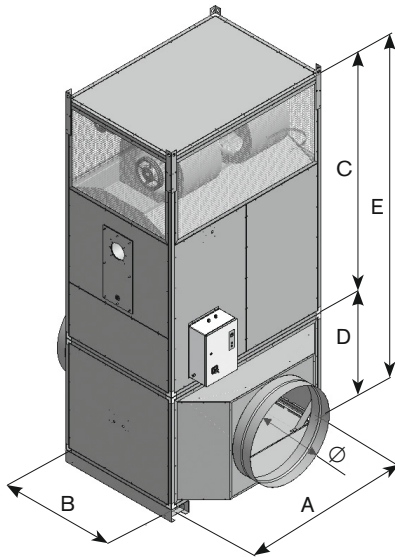

Model	Dimensions mm					Chimney Ø mm	Weight Kg
	A	B	C	D	E		
<b>TC 160 DF</b>	1.300	900	2.120	700	2.820	200	492
<b>TC 190 DF</b>	1.300	900	2.120	700	2.820	200	517
<b>TC 225 DF</b>	1.500	1.000	2.120	700	2.820	250	620
<b>TC 255 DF</b>	1.500	1.000	2.120	700	2.820	250	625
<b>TC 320 DF</b>	1.700	1.200	2.350	1.100	3.450	250	834
<b>TC 390 DF</b>	1.700	1.200	2.350	1.100	3.450	250	874
<b>TC 460 DF</b>	2.090	1.270	2.870	1.100	3.970	300	1.222
<b>TC 590 DF</b>	2.090	1.270	2.870	1.100	3.970	300	1.312
<b>TC 645 DF</b>	2.500	1.500	3.120	1.400	4.520	350	1.687
<b>TC 770 DF</b>	2.500	1.500	3.120	1.400	4.520	350	1.812

## TECHNICAL SPECIFICATIONS

## SERIES



Model TC-DF	U.M.	160	190	225	255	320	390	460	590	645	770
<b>Heating capacity input</b>	<b>kW</b>	161,2	190,0	225,8	258,8	322,6	391,0	460,6	590,0	645,3	769,0
	<b>kcal/h</b>	138.600	163.400	194.225	222.600	277.470	336.250	396.160	507.300	554.940	661.500
<b>Heating capacity output</b>	<b>kW</b>	145,3	168,2	203,5	230,3	290,7	347,6	415,0	523,2	581,4	682,9
	<b>kcal/h</b>	125.000	144.600	175.000	198.100	250.000	298.950	356.900	450.000	500.000	587.400
<b>Nominal air flow</b>	<b>Nm³/h</b>	10.600	12.500	14.500	16.000	21.000	23.500	31.000	36.000	42.000	50.000
<b>Useful static pressure</b>	<b>Pa</b>	150	150	150	150	150	150	150	150	150	150
<b>Electrical power</b>	<b>Kw</b>	2,20	3,00	3,00	4,00	4,00	5,50	7,50	7,50	11,00	15,00
<b>Air outlet flange diam.</b>	<b>mm</b>	600	600	600	600	900	900	900	900	1.200	1.200

Technical features certified

# SERIES

# TCO-DF

**Horizontal warm air heater  
with heat exchanger, gas or diesel fired:  
a widespread diffusion of warm air  
at the base of the plants**



#### CERTIFIED IN ACCORDANCE WITH:

MACHINE DIRECTIVE 2006/42/CE

GAS DIRECTIVE 2009/142/CE

LOW TENSION DIRECTIVE 2006/95/CE

ELECTROMAGNETIC COMPATIBILITY  
DIRECTIVE 2004/108/CE

High efficiency warm air heater **TCO "down-flow"** series horizontal version with gas or diesel blown burner provides warm air to be supplied mainly to greenhouse structures, but also in all cases where an air-to-ground diffusion system is required. The equipment consist mainly of an isolated cabinet receiving the air flow produced by the ventilator group. The cabinet contains a high-efficiency inox Aisi 430 stainless steel heat exchanger which transfers the thermal power by means of direct exchange between combustion products and the air flow to be treated. The warm air heater with air diffusion system consisting of main sleeves with secondary branch sleeves, **allows the targeted heating of plant's base granting a more intensive growth and a global energy saving.** The centrifugal fan's characteristics make the equipment suitable to be installed where air is to be distributed through air channels or more generally where high static pressure is required. The warm air heater is complete with electrical device for heater functions control and a particular flange for the connection to air channels.

On request all the models can be matched with double stage or modulating burners for the total control of the greenhouse's temperature. This allows to reach the maximum global plant efficiency.

## CONSTRUCTIVE PECULIARITIES

- Fan group - includes one or more centrifugal double intake fans, statically and dynamically balanced, driven through a variable gear transmission by an electric motor complete with belt tightner.
- Electric equipment - for automatic or manual fan control and for the emergency stop of the burner in case of air overheating. Inclusive of electric switchboard and FAN-LIMIT double thermostat.

#### High efficiency heat exchanger.

- Combustion chamber - made of inox Aisi 430 18% chromium stainless steel, flame-inversion model with low thermal load, cylindrical or ellipsoidal, perfectly cooled in all of its points.
- Exchange elements - made of inox Aisi 430 18% chromium stainless steel plate exhaust flues, flat tubular sections, with special prints for maximum thermal efficiency.
- Exhaust manifold - front and rear, made of inox Aisi 430 18% chromium stainless steel, with wide inspection doors for rational and easy cleaning.

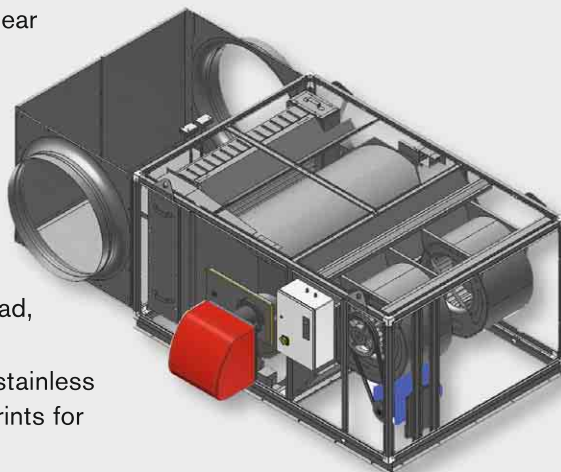



## DIMENSIONS

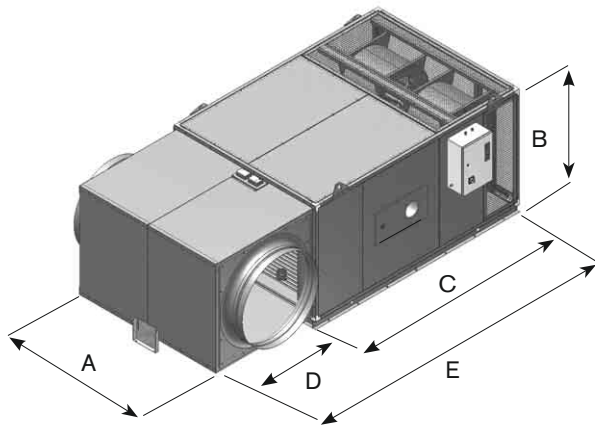

Model	Dimensions mm					Chimney Ø mm	Weight Kg
	A	B	C	D	E		
<b>TCO 160 DF</b>	1.300	900	2.120	700	2.820	200	492
<b>TCO 190 DF</b>	1.300	900	2.120	700	2.820	200	517
<b>TCO 225 DF</b>	1.500	1.000	2.120	700	2.820	250	620
<b>TCO 255 DF</b>	1.500	1.000	2.120	700	2.820	250	625
<b>TCO 320 DF</b>	1.700	1.200	2.350	1.100	3.450	250	834
<b>TCO 390 DF</b>	1.700	1.200	2.350	1.100	3.450	250	874
<b>TCO 460 DF</b>	2.090	1.270	2.870	1.100	3.970	300	1.222
<b>TCO 590 DF</b>	2.090	1.270	2.870	1.100	3.970	300	1.312
<b>TCO 645 DF</b>	2.500	1.500	3.120	1.400	4.520	350	1.687
<b>TCO 770 DF</b>	2.500	1.500	3.120	1.400	4.520	350	1.812

## TECHNICAL SPECIFICATIONS

## SERIES TCO-DF

Model TCO-DF	U.M.	160	190	225	255	320	390	460	590	645	770
Heating capacity input	<b>kW</b>	161,2	190,0	225,8	258,8	322,6	391,0	460,6	590,0	645,3	769,0
	<b>kcal/h</b>	138.600	163.400	194.225	222.600	277.470	336.250	396.160	507.300	554.940	661.500
Heating capacity output	<b>kW</b>	145,3	168,2	203,5	230,3	290,7	347,6	415,0	523,2	581,4	682,9
	<b>kcal/h</b>	125.000	144.600	175.000	198.100	250.000	298.950	356.900	450.000	500.000	587.400
Nominal air flow	<b>Nm³/h</b>	10.600	12.500	14.500	16.000	21.000	23.500	31.000	36.000	42.000	50.000
Useful static pressure	<b>Pa</b>	150	150	150	150	150	150	150	150	150	150
Electrical power	<b>Kw</b>	2,20	3,00	3,00	4,00	4,00	5,50	7,50	7,50	11,00	15,00
Air outlet flange diam.	<b>mm</b>	600	600	600	600	900	900	900	900	1.200	1.200

Technical features certified

# SERIES

# SUPERCIKKI 80



**Direct-fired gas heater:  
high efficiency,  
safety, convenience.**

**CERTIFIED IN ACCORDANCE WITH:**

**MACHINE DIRECTIVE 2006/42/CE**

**GAS DIRECTIVE 2009/142/CE**

**LOW TENSION DIRECTIVE 2006/95/CE**

**ELECTROMAGNETIC COMPATIBILITY  
DIRECTIVE 2004/108/CE**

**Direct-fired gas air heater Supercikki 80 with 100% thermal efficiency.**

A special atmospheric anti-dust gas burner assures high performance either with methane, propane or butane gas. **High safety level** is guaranteed thanks to hot surface ignition and flame control by ionisation, double thermostats and flow switch. The flame is completely inside the heater and is protected by combustion circuit with aluminium steel plate, resistant to high temperature and corrosion.

Solid external casing is made of pre-painted galvanized steel or in stainless steel with IP 44 protection degree which makes the heater **totally weather-proof** and can be either installed indoor or outdoor.

The external cabinet can be easily disassembled without disconnecting wires, for very quick and simple accessibility and maintenance operations. Special radial fan assures a high air throw speed from the air duct for the perfect distribution of the heat.

**Supercikki 80 is the ideal solution for greenhouse or livestock buildings heating.**

## SUPERCIKKI 80: installation example in greenhouse



## SUPERCIKKI 80: installation example in greenhouse or outside



## ACCESSORIES

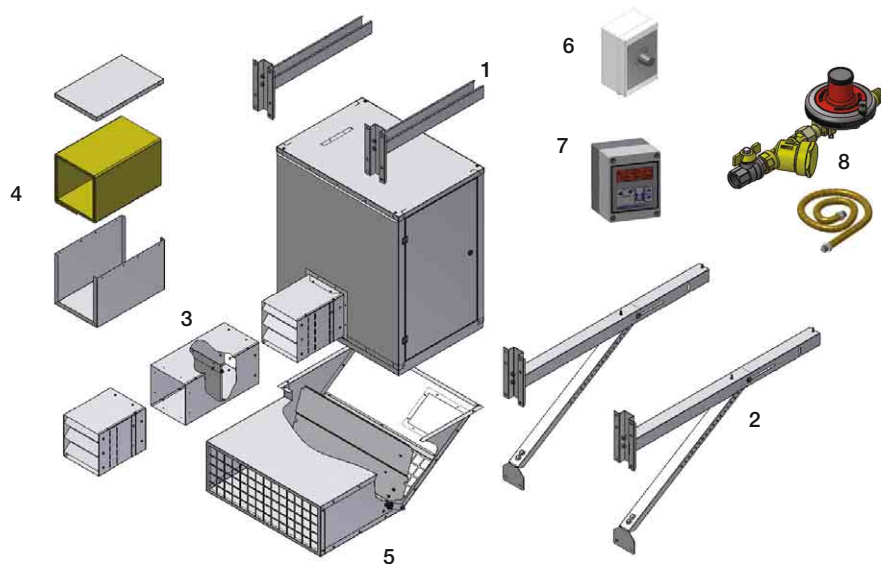

Dimensions, mm			Weight kg
Lenght	Wide	Height	
706	492	800	63

1. Standard support brackets.
2. Special long support brackets.
3. Outlet extension with gravity damper (50 or 70 cm).
4. Isolation kit for outlet extension (50 o 75 cm).
5. Air recirculation plenum with damper.
6. Electronic thermostat.
7. Electronic thermostat with digital display.
8. Gas connection kit.

## TECHNICAL SPECIFICATIONS SERIES SUPERCIKKI 80

Model SUPERCIKKI	Unit	80
Heating capacity output	kW	80,0
	kcal/h	68.800
Air flow rate	m <sup>3</sup> /h	2.000
Air temperature deviation ( $\Delta T$ )	K	145
Air throw	m	30
Monophase electrical supply	F+N+T	230V - 50 Hz

⚠ On request INOX casing and customized technical features are available.

# SERIES

# AZN-X



## Water air heaters suitable for agricultural applications

### CERTIFIED IN ACCORDANCE WITH:

MACHINE DIRECTIVE 2006/42/CE

LOW TENSION DIRECTIVE 2006/95/CE

ELECTROMAGNETIC COMPATIBILITY  
DIRECTIVE 2004/108/CE

**AZN-X water air heaters** have a wide range of models with the capacity going from **13 kW to 114 kW**. Water air heaters **AZN-X** have **stainless steel** casings and are equipped with heat exchangers with copper tubes and aluminium fins. They can be either fixed on support brackets or suspended.

The low noise fan can be provided with electric motors for operation at two or three speeds.

The heaters **AZN-X** are supplied with the hot water produced by a separate boiler, they are particularly suitable for the greenhouses that have either **natural gas/biogas of their own production or cogeneration systems** which provide hot water.

The heaters AZN-X can also operate **in a cooling mode** if properly supplied with cold water.

No combustion inside the building, no need for the fuel supply or for smoke exhaust systems.

**The clean and dry hot air ensures optimal growth of the plants.**

## MAIN COMPONENTS

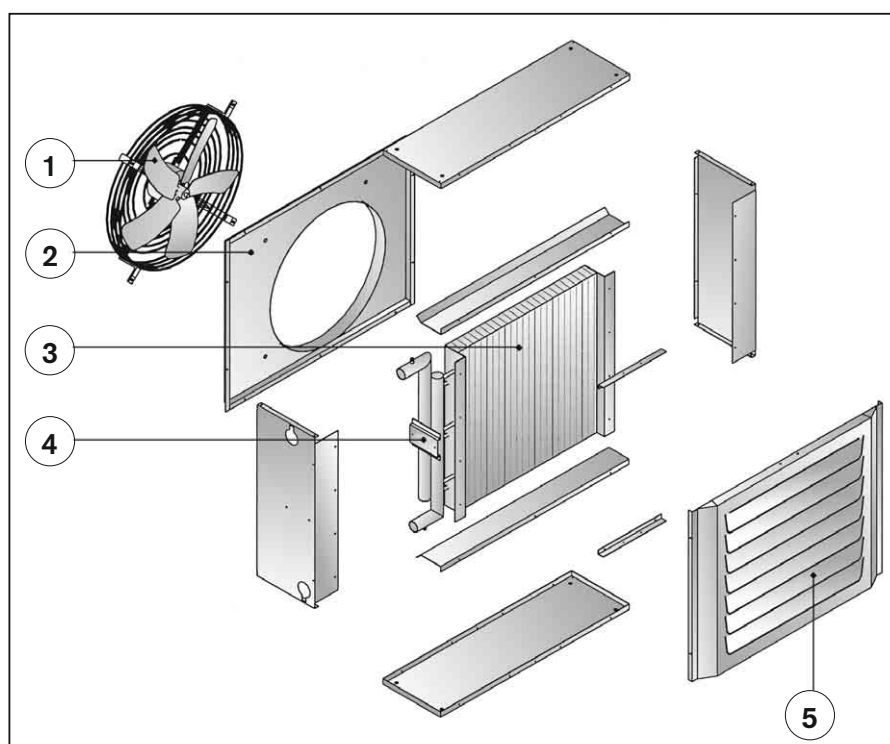

1. Electric fan with safety protection grid.
2. Fan panel.
3. Exchange battery in copper with aluminium fins.
4. Collector with upper and bottom air vent and anti-torsion plate.
5. Removable front panel with horizontal diffusion fins. orizzontali o bidirezionali.

### AZN SERIES IS ALSO AVAILABLE IN FOLLOWING VERSIONS:

AZN: with casing in galvanized painted steel;

AZN-F: for heating and cooling, with condensate tray;

AZN-CT: with cataphoresis treated coil.

**△ Customized technical features are available on request.**



# AZN-X: installation examples in greenhouses



## DIMENSIONS

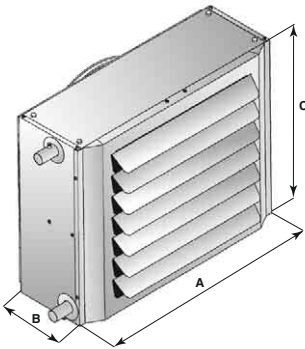

Model	Dimensions mm			Weight kg
	A	B	C	
AZN-X 12	555	280	390	14
AZN-X 13	555	280	390	15
AZN-X 22	605	280	440	16
AZN-X 23	605	280	440	18
AZN-X 32	655	280	490	19
AZN-X 33	655	280	490	21
AZN-X 42	705	280	540	23
AZN-X 43	705	280	540	24
AZN-X 52	755	280	590	25

Model	Dimensions mm			Weight kg
	A	B	C	
AZN-X 53	755	280	590	28
AZN-X 62	805	280	640	29
AZN-X 63	805	280	640	32
AZN-X 72	855	280	690	40
AZN-X 73	855	280	690	43
AZN-X 82	1.205	280	690	58
AZN-X 83	1.205	280	690	63
AZN-X 92	1.405	280	690	70
AZN-X 93	1.405	280	690	76

## TECHNICAL SPECIFICATIONS

## SERIES AZN-X

Model AZN-X	USEFUL heating capacity output <sup>(1)</sup>		Rows N°	Fan rpm max-med-min	Fan N°	Max. air flow	Air throw <sup>(2)</sup>	Water pressure drop	Water flow rate	Electr. supply	Electr. power	Sound pressure [dB (A)] <sup>(3)</sup>	
	kW	kcal/h										max. speed	min. speed
12	13,3	11.450	2	1.400 900 700	1	1.750	22	26	785	230 ~	73	50	41
13	17,3	14.900	3		1	1.550	17	20	1.020		73	50	41
22	17,7	15.250	2		1	2.450	25	17	1.044		105	51	45
23	23,8	20.450	3		1	2.300	19	20	1.401		105	51	45
32	22,0	18.950	2		1	2.800	31	30	1.296		110	52	43
33	28,5	24.550	3		1	2.550	25	17	1.680		110	52	43
42	27,4	23.550	2		1	3.600	31	24	1.612		130	53	43
43	35,4	31.300	3		1	3.400	25	19	2.141		130	53	43
52	31,9	27.400	2		1	3.950	32	20	1.876		160	53	43
53	42,7	36.750	3		1	3.900	24	13	2.514		160	53	43
62	39,1	33.600	2		1	5.200	33	13	2.300		200	53	47
63	52,4	45.100	3		1	4.900	26	16	3.086		200	53	47
72	47,4	40.800	2		1	6.700	39	14	2.793		245	52	46
73	63,0	54.150	3		1	6.200	37	12	3.707		245	52	46
82	67,7	58.200	2	2	8.500	38	11	3.985	260	54	49		
83	87,8	75.550	3	2	7.700	32	9	5.173	260	54	49		
92	88,8	76.400	2	2	12.550	40	21	5.229	500	53	48		
93	114,9	98.800	3	2	10.900	38	17	6.764	500	53	48		

(1) Heating: air inlet temperature 15°C, water temperature 85-70 °C, relative humidity 50%, atmospheric pressure 1013 mbar, at maximal fan speed.

(2) Distance from the equipment where with remaining air speed of 0,2 m/s.

(3) Equipment installed on the wall, at 3 meter distance from the floor, maximal and minimal fan speed, measured in free field.

# SERIES

# DAE



## Universal recirculation fans for agricultural applications

### CERTIFIED IN ACCORDANCE WITH:

MACHINE DIRECTIVE 2006/42/CE

LOW TENSION DIRECTIVE 2006/95/CE

ELECTROMAGNETIC COMPATIBILITY DIRECTIVE 2004/108/CE

**DAE** are recirculation fans produced with a scope to guarantee an optimal diffusion of the warm air in the environments, avoiding the formation of stagnant zones at different temperature and humidity conditions. This offers several advantages: a more comfortable ambient and a more rational use of thermal energy introduced, a significant reduction of the risk of formation of condensate on the walls which creates a favorable environment for the reproduction of molds and parasites.

## TECHNICAL SPECIFICATIONS

## SERIES DAE

Model DAE	U.M.	500	600
Nominal air flow at 0 Pa	m <sup>3</sup> /h	4.000	7.000
Air throw	m	15	19
Electrical power	W	90	150
Electrical supply		230V 50Hz	230V 50Hz
Fan rotation	round/min'	880	880
Sound pressure at 6 meters	dB (A)	45	46

## DAE: installation examples in greenhouses



## Heating of greenhouses

TAIWAN

YEAR	<b>2010/2016</b>
SERIES	<b>AGRI</b>
TOTAL POWER	<b>22.000 kW</b>



### REQUEST

Heating of greenhouses for production of orchids.  
System working with frequency 60 Hz.  
Gas or diesel fuel.

### SOLUTION

180 suspended warm air heaters AGRI series.  
Fan and burner for frequency 60 Hz.  
Suspended version complete with accessories.

### ADVANTAGES

Efficient and immediate heating.  
Simplified installation.  
Autonomous heaters complete with accessories.  
Units ready to use.

## Heating of greenhouses

MEXICO

YEAR	2007 / 2014
SERIES	TC-DF
TOTAL POWER	40.000 kW



### REQUEST

Heating of industrial multitunnel greenhouses for intensive tomatoes cultivation with hydroponic technique.

Total area of 35 hectares.

Ground air distribution through perforated sleeves.

Reduced consumptions and low installation costs.

### SOLUTION

116 condensing warm air heaters TC-DF series.

LPG modulating burners.

Air distribution and diffusion system with perforated polyethylene sleeves placed along the rows of the plants.

Configuration for remote control management.

### ADVANTAGES

Whole system costs considerably reduced compared to solutions with centralized hot water boiler.

Heat spread from the ground, widespread with uniformity.

Low thermal inertia, working by different zones, high reliability.

Designed pattern of the sleeves holes for an ideal heat distribution.

## Heating of greenhouses

ITALY

YEAR	<b>2012</b>
SERIES	<b>AGRI</b>
TOTAL POWER	<b>400 kW</b>



### REQUEST

Heating of greenhouses for cultivation of seedling and plants on tables  
 Fuel: diesel oil  
 Air diffusion: down-flow by channels

### SOLUTION

High efficiency mobile warm air heaters AGRI-C series  
 Decentralized heating with a possibility of temperature control by zones  
 Air distribution through the use of polyethylene perforated sleeves placed under the tables

### ADVANTAGES

The heat is uniformly distributed from the bottom.  
 The possibility of heating by zones with different temperatures.  
 The units can be easily moved in case of changes in the layout of the greenhouse.  
 Reduction of the air stratification and very low thermal inertia.  
 Reduction of installation and operation costs compared to traditional water heating systems

## Heating of greenhouses

EGYPT

YEAR	<b>2017-2018</b>
SERIES	<b>AGRI-DF</b>
TOTAL POWER	<b>761.500 kW</b>



### REQUEST

Heating of industrial greenhouses for intensive vegetables cultivation.  
 Diesel oil fuel.  
 Air diffusion: down-flow by air ducts and sleeves.  
 Simple, convenient and reliable heating solution.

### SOLUTION

High efficiency warm air heaters AGRI-DF series complete with load-bearing two way air diffusion outlet for easy principal air ducts connection.  
 High performance axial electrical fan suitable for air diffusion by air ducts and channels.  
 Decentralized heating with possibility of temperature control by zones.  
 Air distribution through polyethylene perforated sleeves placed along the rows.

### ADVANTAGES

Targeted and capillary crop heating from the bottom only where needed and at the moment of actual need, with no fuel or energy waste.  
 Direct “down-flow” crop heating increases the growth intensity and cultivations development, promoting more frequent cultivation cycles.  
 Possibility of heating by zones with different temperatures.  
 Air stratification decrease and very low thermal inertia.  
 Lower installation and operation costs compared to traditional water heating systems.

## Heating of greenhouses

AZERBAIJAN

YEAR	<b>2014-2015</b>
SERIES	<b>TC-DF</b>
TOTAL POWER	<b>6.300 kW</b>



### REQUEST

Heating of industrial multitunnel greenhouses for intensive tomatoes cultivation with hydroponic technique.  
 Heating with natural gas and diesel oil.  
 Reduced consumption and low installation costs

### SOLUTION

12 condensing warm air heaters TC-DF series.  
 Two-stages dual burners working with natural gas and diesel oil.  
 Air distribution and air diffusion system with perforated polyethylene sleeves placed along the rows of the plants.  
 Configuration for remote control management.

### ADVANTAGES

High reliability thanks to the dual-fuel burners.  
 Whole system costs considerably reduced compared to solutions with centralized hot water boiler.  
 Heat spread from the ground, widespread with uniformity.  
 Low thermal inertia, working by different zones.  
 Designed pattern of the sleeves holes for the ideal heat distribution.

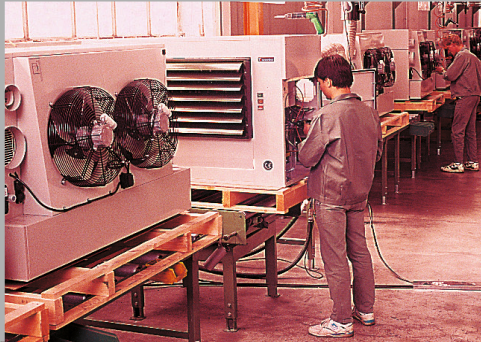

### TECNOCLIMA S.p.A.

Tecnoclima S.p.A. was founded in 1973 by Alfonso Vescovi and extends over a surface area of 50.000 square meters.

Its purpose is to produce equipment for air treatment, heating and conditioning.

For more than 40 years the **production takes place entirely in Italy**, in the historic production site near Trento.

#### TECNOCLIMA GROUP:

- TECNOCLIMA S.p.A.** Pergine (Trento) Italia
- EMAT S.A.** Genas (Lyon) France
- OOO TC Group Energia** Moscow Russia

#### BRANDS:

- TECNOCLIMA** well-known worldwide for its high quality equipment for air heating and air treatment
- CLIMA ITALIA** prestigious brand in the air conditioning sector
- EMAT** France leader company in the warm air heating and air treatment



#### PRODUCTS AND TECHNOLOGIES:

**Standard products** with more than 300 models of warm air heaters, roof top, air treatment units, heat pumps, heat recovery units and hydronic terminal units.

**Special products:** specifically designed and manufactured according to customer's specifications.

**Advanced technologies:** condensation with modulating and premix burner, variable air flow with inverter, plug-fans, static and thermodynamic recovery, regulations and controls with dedicated software internally developed.

#### APPLICATIONS:

##### Heating, Ventilation and Air Conditioning:

- Halls and warehouses for industrial and commercial use
- Greenhouses and farms
- Places of worships
- Tensostatic structures and air domes
- Temporary structures, tents and rental structures
- Residential sector

##### Clean high temperature air for process applications:

- Painting
- Drying
- Heat treatment
- Polymerization
- Food industry processes

#### EXPORT COUNTRIES:

Argentina, Australia, Austria, Azerbaijan, Belgium, Byelorussia, Bulgaria, Bosnia, Chile, China, Cyprus, Colombia, Croatia, Denmark, Egypt, France, Germany, Jordan, Grain Britain, Greece, Hungary, India, Israel, Chorea, Lebanon, Lithuania, Malta, Norway, Nederland, Poland, Portugal, Romania, Chez Republic, Moldova Republic, Slovakia Republic, San Marino Republic, Russia, Serbia, Slovenia, Spain, Sweden, Switzerland, South Africa, Taiwan, Turkey, Ukraine, Uruguay, New Zealand.



TECNOCLIMA S.p.A.

Viale Industria, 19 - 38057 Pergine Valsugana (TN) - Italy

phone +39 0461 531676 - fax +39 0461 512432

www.tecnoclimaspa.com - tecnoclima@tecnoclimaspa.com

#### INTERNATIONALLY RECOGNIZED QUALITY



Since the Company is constantly focused on products' improvements, all equipment and accessories may be subjected to alterations and modifications without notice.